

NEST BOX CONSTRUCTION FOR WILDLIFE



Building nest boxes for wildlife provides a much needed solution for those animals dependent on tree hollows for shelter and nesting. Over the years our forests have been modified, leaving them quite 'young'. Therefore tree hollows have not formed sufficiently to provide these much needed homes. The Broken Boosey and Whroo Goldfields Conservation Management Networks have been working hard over the past five years building, installing and monitoring nest boxes for sugar gliders and brush-tailed phascogales. Below are instructions on how to construct your own nest box. The boxes can be of any size, our wildlife aren't fussy!

- Nest boxes are glued together and fixed with screws or nails.
- The mounting timber is fixed to the box with a 10mm bolt to allow some movement when mounting on a tree that is not level.
- The enter hole is around 40mm and it could be placed on the side or back. Results from monitoring show that having the hole at the back is more effective.
- The inside partition is placed at 45 degree angle in front of hole.
- The main part of the nest box is made from 13 mm plywood (using marine plywood will help it last longer, as will painting the edges).
- The lid has a small overhang to protect the rest of the timber from the weather. This overhang also makes the lid easy to hold and lift when inspecting inside the box.
- The boxes are fixed to the tree with two 75mm or 100mm galvanized nails with two washers. This allows for the movement when the tree grows (vertical mounting is desired).
- The hinge on the side works better for inspection.

For more information on nest boxes, visit www.latrobe.edu.au/wildlife/nursery/nestboxes



Photo: Sugar gliders in nest box. O Talamo 2012.

Interior view of a nest box

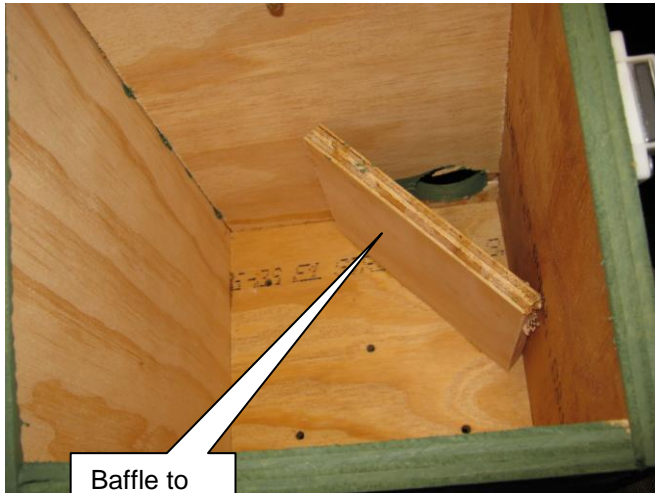

Baffle to inhibit birds using the nest box

Exterior view of a nest box

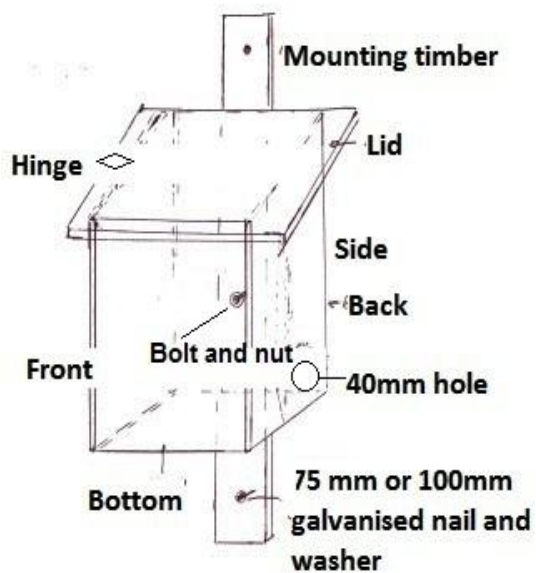

NEST BOX SPECIFICATIONS:

Use 13mm plywood

Mounting timber: 75 x 21 x 650mm

Lid: 260 x 235mm

Side (front): 240 x 205mm

Side (back): 290 x 180mm

Back: 290 x 180mm

Bottom: 175 x 180mm

Front: 235 x 180mm

Baffle: 150 x 120mm

Angle for lid: 78°

Hole in back: 40mm

Use marine ply or hardwood timber, not treated pine. Paint the box for protection from the weather, as well as for camouflage.